

## ECO Lines F80 LED Line Projector

Projects a thick, permanent floor line that eliminates the need for maintenance required by floor tape and paint lines.

- **3rd Generation: Crisper, longer lines at increased brightness**
- **Designed for Rugged Environments and long service life**
- **Focusable for optimal line appearance and brightness**
- **Maintenance free, no fans or motors**
- **Adjustable line length option**



### SPECIFICATIONS

Item Codes:	EL-F80Y (yellow), EL-F80A (amber), EL-F80G (green), EL-F80B (blue), EL-F80R (red), EL-F80W (white)
Power Supply:	100-240/277VAC, 50/60Hz (Voltage Range: 90-305VAC, 48-63Hz; 127-431VDC)
Power Draw:	140W, 1.6A/115V, 0.7A/277V
Driver:	MOSO X6-150M041 (integrated)
Inrush Current:	COLD START 75A (t width=570µs at 50% I peak) at 230VAC per NEMA 410
Breakers:	We recommend lighting specific breakers at 70% of specified load
Power Cord:	Length: 8.75' (2.65m), Power Plug: Nema 5-15 (other plug options, such as L7-15P available)
Control Input Signals:	On/Off or Dimming: 1-10V, 10-100KOhm, PWM, Dry Switch

Environmental Rating:	Driver: IP67, Projector: IP65
Safety Standards:	EC: EN IEC 60598-1:2021, N IEC 60598-2-1:2021, Driver: UL E334687
Temperature Range:	-22°F to 113°F (-30°C to 45°C)

LED Life:	35,000h until 30% brightness loss is reached (L70*) (*L70= the time to 30% brightness loss)
Driver Life:	MTBF: 200,000h, lifetime: 100,000h at tc=75°C and 80% load (driver and LED are field serviceable)

Projection Colors:	Yellow, Green, Red, Blue, Amber, White (colors are changeable by swapping the LED)		
Line Width:	3 to 6" (75 to 150mm)		
Projection Lenses:	53° (1:0.93 throw ratio)	73° (1:1.4 throw ratio)	90° (1:1.86 throw ratio)

Typ. Projection Range / Size	Bright Environment	Average Env.	Dim Env.
Typ. Usable Line Length:	36-45' (11-14m)	48-56' (15-17m)	80' (24m)
At typ. Distance:	20/27/41' (6/8/13m)	26/34/52' (7.5/10/15m)	43/65/86' (12/16/24m)
Line Length Adjustment:	Yes, with optional blinders (the min. length is approx. 30% of the full line length)		

Product Warranty:	Two years from date of purchase
-------------------	---------------------------------

## DIMENSIONS AND WEIGHT

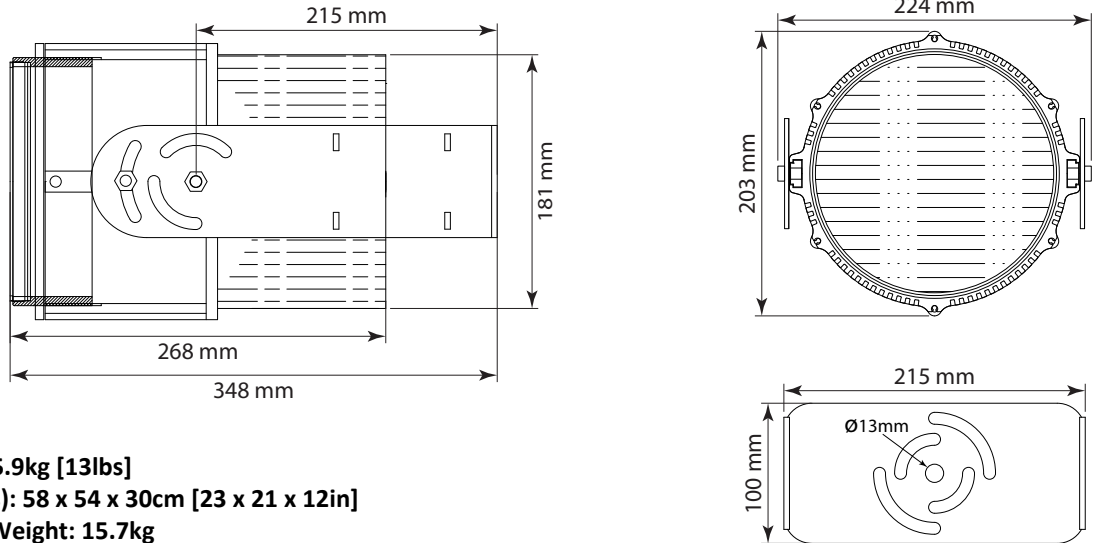

Dimensions in mm  
 Weight incl. Driver: 5.9kg [13lbs]  
 Master Carton (2 pcs): 58 x 54 x 30cm [23 x 21 x 12in]  
 Master Carton Dim Weight: 15.7kg

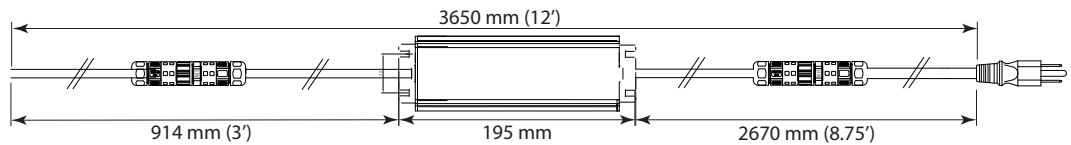

## PHOTOMETRICS

ECO Lines™ Photometrics (Imperial values, select colors, see <a href="http://gobosource.com">gobosource.com</a> for complete Photometrics)															
Model	Lens	Beam Mult.	Value	PROJECTION DISTANCE IN FEET (ft)											
				9	12	15	20	24	30	36	39	46	52	60	66
ECO Lines F80 Green	53°	0.93	Length (ft)	8.4	11.2	14.0	18.6	22.3	27.9	33.5	36	43	48	56	61
			Brightn.(fc)	1889	1063	680	383	266	170	118	101	72	57	43	35
	73°	1.40	Length (ft)	12.6	16.8	21.0	28.0	33.6	42.0	50.4	54.6	64.4	72.8	84.0	92.4
Brightn.(fc)			1522	856	548	308	214	137	95	81	58	46	34	28	
90°	1.86	Length (ft)	16.7	22.3	27.9	37.2	45	56	67	73	86	97	112	123	
		Brightn.(fc)	1322	744	476	268	186	119	83	70	51	40	30	25	
ECO Lines F80 Yellow	53°	0.93	Length (ft)	8.4	11.2	14.0	18.6	22.3	27.9	33.5	36	43	48	56	61
			Brightn.(fc)	1556	875	560	315	219	140	97	83	60	47	35	29
	73°	1.40	Length (ft)	12.6	16.8	21.0	28.0	33.6	42.0	50.4	54.6	64.4	72.8	84.0	92.4
Brightn.(fc)			1278	719	460	259	180	115	80	68	49	38	29	24	
90°	1.86	Length (ft)	16.7	22.3	27.9	37.2	45	56	67	73	86	97	112	123	
		Brightn.(fc)	1011	569	364	205	142	91	63	54	39	30	23	19	
ECO Lines F80 Amber	53°	0.93	Length (ft)	8.4	11.2	14.0	18.6	22.3	27.9	33.5	36	43	48	56	61
			Brightn.(fc)	889	500	320	180	125	80	56	47	34	27	20	17
	73°	1.40	Length (ft)	12.6	16.8	21.0	28.0	33.6	42.0	50.4	54.6	64.4	72.8	84.0	92.4
Brightn.(fc)			744	419	268	151	105	67	47	40	28	22	17	14	
90°	1.86	Length (ft)	16.7	22.3	27.9	37.2	45	56	67	73	86	97	112	123	
		Brightn.(fc)	611	344	220	124	86	55	38	33	23	18	14	11	

© 2024 Gobosource. Gobosource is a Registered Trademark of Globus New Media LLC

### How to Read the Illumination Values

700+	Extreme brightness for extremely bright environments, extremely bright production environments (no direct sunlight).
180-700	Very high brightness for very bright environments, such as very bright production floor.
90-180	The most common brightness bracket for regular production floors and modern warehouses.
60-90	Sufficient brightness for bright and medium bright warehouses.
40-60	Sufficient brightness for dim facilities.

**Questions? 614-583-5749 info@forklifttrainingsystems.com**